

# CHICAGO

## Electric<sup>®</sup>Power Tools

# 9.5 AMP MAGNESIUM RECIPROCATING SAW

**Model 97580**

## SET UP AND OPERATING INSTRUCTIONS



Visit our website at: <http://www.harborfreight.com>



**Read this material before using this product.  
Failure to do so can result in serious injury.  
SAVE THIS MANUAL.**

Copyright© 2008 by Harbor Freight Tools®. All rights reserved. No portion of this manual or any artwork contained herein may be reproduced in any shape or form without the express written consent of Harbor Freight Tools. Diagrams within this manual may not be drawn proportionally. Due to continuing improvements, actual product may differ slightly from the product described herein.

**For technical questions or replacement parts, please call 1-800-444-3353.**

---

## SAVE THIS MANUAL

---

Keep this manual for the safety warnings and precautions, assembly, operating, inspection, maintenance and cleaning procedures. Write the product's serial number in the back of the manual near the assembly diagram (or month and year of purchase if product has no number). Keep this manual and the receipt in a safe and dry place for future reference.

---

## IMPORTANT SAFETY INFORMATION

---

In this manual, on the labeling, and all other information provided with this product:



This is the safety alert symbol. It is used to alert you to potential personal injury hazards. Obey all safety messages that follow this symbol to avoid possible injury or death.

**⚠ DANGER** DANGER indicates a hazardous

situation which, if not avoided, will result in death or serious injury.

**⚠ WARNING** WARNING indicates a hazardous situation which, if not avoided, could result in death or serious injury.

**⚠ CAUTION** CAUTION, used with the safety alert symbol, indicates a hazardous situation which, if not avoided, could result in minor or moderate injury.

**NOTICE** NOTICE is used to address practices not related to personal injury.

**CAUTION** CAUTION, without the safety alert symbol, is used to address practices not related to personal injury.

---

### General Power Tool Safety Warnings



**WARNING** Read all safety warnings and instructions. *Failure to follow the warnings and instructions may result in electric shock, fire and/or serious injury. Save all warnings and instructions for future reference. The term "power tool" in the warnings refers to your mains-operated (corded) power tool or battery-operated (cordless) power tool.*

1. **Work area safety**
  - a. **Keep work area clean and well lit.** *Cluttered or dark areas invite accidents.*
  - b. **Do not operate power tools in explosive atmospheres, such as in the presence of flammable liquids, gases or dust.** *Power tools create sparks which may ignite the dust or fumes.*
  - c. **Keep children and bystanders away while operating a power tool.**

*Distractions can cause you to lose control.*

## 2. Electrical safety

- a. **Power tool plugs must match the outlet. Never modify the plug in any way. Do not use any adapter plugs with grounded power tools. Unmodified plugs and matching outlets will reduce risk of electric shock.**
- b. **Avoid body contact with grounded surfaces such as pipes, radiators, ranges and refrigerators. There is an increased risk of electric shock if your body is grounded.**
- c. **Do not expose power tools to rain or wet conditions. Water entering a power tool will increase the risk of electric shock.**
- d. **Do not abuse the cord. Never use the cord for carrying, pulling or unplugging the power tool. Keep cord away from heat, oil, sharp edges or moving parts. Damaged or entangled cords increase the risk of electric shock.**
- e. **When operating a power tool outdoors, use an extension cord suitable for outdoor use. Use of a cord suitable for outdoor use reduces the risk of electric shock.**
- f. **If operating a power tool in a damp location is unavoidable, use a Ground Fault Circuit Interrupter (GFCI) protected supply. Use of a GFCI reduces the risk of electric shock.**

## 3. Personal safety

- a. **Stay alert, watch what you are doing and use common sense when operating a power tool. Do**

**not use a power tool while you are tired or under the influence of drugs, alcohol or medication. A moment of inattention while operating power tools may result in serious personal injury.**

- b. **Use safety equipment. Always wear ANSI-approved eye protection. Safety equipment such as dust mask, non-skid safety shoes, hard hat, or hearing protection used for appropriate conditions will reduce personal injuries.**
- c. **Prevent unintentional starting. Ensure the switch is in the off-position before connecting to power source and/or battery pack, picking up or carrying the tool. Carrying power tools with your finger on the switch or energizing power tools that have the switch on invites accidents.**
- d. **Remove any adjusting key or wrench before turning the power tool on. A wrench or a key left attached to a rotating part of the power tool may result in personal injury.**
- e. **Do not overreach. Keep proper footing and balance at all times. This enables better control of the power tool in unexpected situations.**
- f. **Dress properly. Do not wear loose clothing or jewelry. Keep your hair, clothing and gloves away from moving parts. Loose clothes, jewelry or long hair can be caught in moving parts.**
- g. **If devices are provided for the connection of dust extraction and collection facilities, ensure these are connected and properly used.**

*Use of these devices can reduce dust-related hazards.*

4. **Power tool use and care**
  - a. **Do not force the power tool. Use the correct power tool for your application.** *The correct power tool will do the job better and safer at the rate for which it was designed.*
  - b. **Do not use the power tool if the switch does not turn it on and off.** *Any power tool that cannot be controlled with the switch is dangerous and must be repaired.*
  - c. **Disconnect the plug from the power source and/or the battery pack from the power tool before making any adjustments, changing accessories, or storing power tools.** *Such preventive safety measures reduce the risk of starting the power tool accidentally.*
  - d. **Store idle power tools out of the reach of children and do not allow persons unfamiliar with the power tool or these instructions to operate the power tool.** *Power tools are dangerous in the hands of untrained users.*
  - e. **Maintain power tools. Check for misalignment or binding of moving parts, breakage of parts and any other condition that may affect the power tool's operation. If damaged, have the power tool repaired before use.** *Many accidents are caused by poorly maintained power tools.*
  - f. **Keep cutting tools sharp and clean.** *Properly maintained cutting tools with sharp cutting edges are less likely to bind and are easier to control.*

- g. **Use the power tool, accessories and tool bits etc. in accordance with these instructions, taking into account the working conditions and the work to be performed.** *Use of the power tool for operations different from those intended could result in a hazardous situation.*

#### 5. **Service**

- a. **Have your power tool serviced by a qualified repair person using only identical replacement parts.** *This will ensure that the safety of the power tool is maintained.*

---

### **Reciprocating Saw Safety Warnings**

1. **Hold power tool by insulated gripping surfaces when performing an operation where cutting tool may contact hidden wiring or its own cord.** *Contact with a "live" wire will make exposed metal parts of the tool "live" and shock the operator.*
2. **Use clamps or another practical way to secure and support the work piece to a stable platform.** *Holding the work by hand or against your body leaves it unstable and may lead to loss of control.*
3. Maintain labels and nameplates on the tool. These carry important safety information. If unreadable or missing, contact Harbor Freight Tools for a replacement.
4. Avoid unintentional starting. Prepare to begin work before turning on the tool.
5. Do not lay the tool down until it has come to a complete stop. Moving

parts can grab the surface and pull the tool out of your control.

6. When using a handheld power tool, maintain a firm grip on the tool with both hands to resist starting torque.
7. Do not leave the tool unattended when it is plugged into an electrical outlet. Turn off the tool, and unplug it from its electrical outlet before leaving.
8. This product is not a toy. Keep it out of reach of children.
9. People with pacemakers should consult their physician(s) before use. Electromagnetic fields in close proximity to heart pacemaker could cause pacemaker interference or pacemaker failure. In addition, people with pacemakers should:
  - Avoid operating alone.
  - Do not use with power switch locked on.
  - Properly maintain and inspect to avoid electrical shock.
  - Any power cord must be properly grounded. Ground Fault Circuit Interrupter (GFCI) should also be implemented – it prevents sustained electrical shock.
10. Some dust created by power sanding, sawing, grinding, drilling, and other construction activities, contains chemicals known [to the State of California] to cause cancer, birth defects or other reproductive harm. Some examples of these chemicals are:
  - Lead from lead-based paints
  - Crystalline silica from bricks and cement or other masonry products
  - Arsenic and chromium from chemically treated lumber

Your risk from these exposures varies, depending on how often you do this type of work. To reduce your exposure to these chemicals: work in a well ventilated area, and work with approved safety equipment, such as those dust masks that are specially designed to filter out microscopic particles. (California Health & Safety Code § 25249.5, *et seq.*)

11. **WARNING:** Handling the cord on this product will expose you to lead, a chemical known to the State of California to cause cancer, and birth defects or other reproductive harm. Wash hands after handling. (California Health & Safety Code § 25249.5, *et seq.*)
12. The warnings, precautions, and instructions discussed in this instruction manual cannot cover all possible conditions and situations that may occur. It must be understood by the operator that common sense and caution are factors which cannot be built into this product, but must be supplied by the operator.

### **Vibration Safety**

This tool vibrates during use. Repeated or long-term exposure to vibration may cause temporary or permanent physical injury, particularly to the hands, arms and shoulders. To reduce the risk of vibration-related injury:

1. Anyone using vibrating tools regularly or for an extended period should first be examined by a doctor and then have regular medical check-ups to ensure medical problems are

not being caused or worsened from use. Pregnant women or people who have impaired blood circulation to the hand, past hand injuries, nervous system disorders, diabetes, or Raynaud's Disease should not use this tool. If you feel any medical or physical symptoms related to vibration (such as tingling, numbness, and white or blue fingers), seek medical advice as soon as possible.

2. Do not smoke during use. Nicotine reduces the blood supply to the hands and fingers, increasing the risk of vibration-related injury.
3. Wear suitable gloves to reduce the vibration effects on the user.
4. Use tools with the lowest vibration when there is a choice between different processes.
5. Include vibration-free periods each day of work.
6. Grip tool as lightly as possible (while still keeping safe control of it). Let the tool do the work.
7. To reduce vibration, maintain the tool as explained in this manual. If any abnormal vibration occurs, stop use immediately.



**SAVE THESE INSTRUCTIONS.**

---

## GROUNDING

---

### **⚠️ WARNING**

**TO PREVENT ELECTRIC SHOCK**



**AND DEATH FROM INCORRECT GROUNDING WIRE CONNECTION:**

**Check with a qualified electrician if you are in doubt as to whether the outlet is properly grounded. Do not modify the power cord plug provided with the tool. Never remove the grounding prong from the plug. Do not use the tool if the power cord or plug is damaged. If damaged, have it repaired by a service facility before use. If the plug will not fit the outlet, have a proper outlet installed by a qualified electrician.**

**NOTE: THIS IS A DOUBLE INSULATED TOOL. INFORMATION ON GROUNDED TOOLS IS FOR REFERENCE ONLY.**

---

### **Grounded Tools: Tools with Three Prong Plugs**

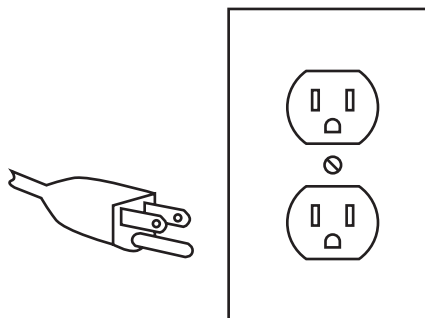

**3-Prong Plug and Outlet**

1. Tools marked with "Grounding Required" have a three wire cord



and three prong grounding plug. The plug must be connected to a properly grounded outlet. If the tool should electrically malfunction or break down, grounding provides a low resistance path to carry electricity away from the user, reducing the risk of electric shock. **(See 3-Prong Plug and Outlet.)**

2. The grounding prong in the plug is connected through the green wire inside the cord to the grounding system in the tool. The green wire in the cord must be the only wire connected to the tool's grounding system and must never be attached to an electrically "live" terminal. **(See 3-Prong Plug and Outlet.)**
3. The tool must be plugged into an appropriate outlet, properly installed and grounded in accordance with all codes and ordinances. The plug and outlet should look like those in the preceding illustration. **(See 3-Prong Plug and Outlet.)**

### Double Insulated Tools: Tools with Two Prong Plugs

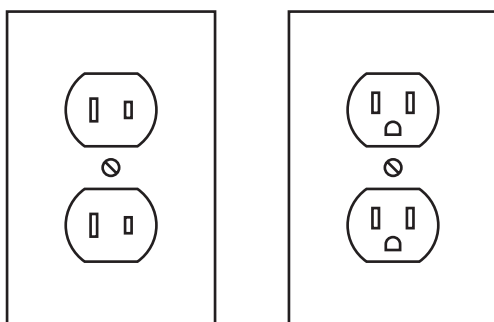

**Outlets for 2-Prong Plug**

1. Tools marked "Double Insulated" do not require grounding. They have a special double insulation system which satisfies OSHA

requirements and complies with the applicable standards of Underwriters Laboratories, Inc., the Canadian Standard Association, and the National Electrical Code. **(See Outlets for 2-Prong Plug.)**

2. Double insulated tools may be used in either of the 120 volt outlets shown in the preceding illustration. **(See Outlets for 2-Prong Plug.)**

### Extension Cords

1. **Grounded** tools require a three wire extension cord. **Double Insulated** tools can use either a two or three wire extension cord.
2. As the distance from the supply outlet increases, you must use a heavier gauge extension cord. Using extension cords with inadequately sized wire causes a serious drop in voltage, resulting in loss of power and possible tool damage. **(See Table A.)** The smaller the gauge number of the wire, the greater the capacity of the cord. For example, a 14 gauge cord can carry a higher current than a 16 gauge cord. **(See Table A.)**
3. When using more than one extension cord to make up the total length, make sure each cord contains at least the minimum wire size required. **(See Table A.)**
4. If you are using one extension cord for more than one tool, add the nameplate amperes and use the sum to determine the required minimum cord size. **(See Table A.)**
5. If you are using an extension cord outdoors, make sure it is marked with







the suffix “W-A” (“W” in Canada) to indicate it is OK for outdoor use.

6. Make sure the extension cord is properly wired and in good electrical condition. Always replace a damaged extension cord or have it repaired by a qualified electrician before using it.
7. Protect the extension cords from sharp objects, excessive heat, and damp or wet areas.

<b>RECOMMENDED MINIMUM WIRE GAUGE FOR EXTENSION CORDS*</b> (120/240 VOLT)					
<b>NAMEPLATE AMPERES</b> (at full load)	<b>EXTENSION CORD LENGTH</b>				
	<b>25'</b>	<b>50'</b>	<b>75'</b>	<b>100'</b>	<b>150'</b>
0 – 2.0	18	18	18	18	16
2.1 – 3.4	18	18	18	16	14
3.5 – 5.0	18	18	16	14	12
5.1 – 7.0	18	16	14	12	12
7.1 – 12.0	18	14	12	10	-
12.1 – 16.0	14	12	10	-	-
16.1 – 20.0	12	10	-	-	-

**TABLE A** \* Based on limiting the line voltage drop to five volts at 150% of the rated amperes.

### Symbology

	Double Insulated
	Canadian Standards Association
	Underwriters Laboratories, Inc.
	Volts Alternating Current
	Amperes
	No Load Revolutions per Minute (RPM)



## SPECIFICATIONS

Electrical Requirements	120 V~ / 60 Hz/9.5 A
Motor No Load Speed	0-2500 RPM
Maximum Cut Depth	6 inches
Length of Stroke	1-1/8 inch
Blade Fastening System	Twist Ring Quick Release Chuck for 1/2" Shank Blades
Required Blade Type	1/2" Shank
Included Blades	Metal Cutting : 4-1/8" x 5/8" x 20ga. 25 TPI Wood Cutting: 5-11/16" x 3/4" x 18 ga. 11TPI
Base Plate Dimensions	3-1/2" L x 1-5/8" W 15 ga. Aluminum
Shoe Plate Tilt Range	80° x 110°
Armature Bearings	(2) Fully Shielded Radial Bearings
Power Control	Trigger Switch with Lock-On Button



## UNPACKING

When unpacking, check to make sure that the item is intact and undamaged. If any parts are missing or broken, please call Harbor Freight Tools at the number shown on the cover of this manual as soon as possible.

### List of contents

Part #	Description	Qty
	Reciprocating Saw	1
43	Wood Cutting Blade	1
43	Metal Cutting Blade	1
67	Allen Key	1
	Owner's Manual	1

## INSTRUCTIONS FOR PUTTING INTO USE



Read the **ENTIRE IMPORTANT SAFETY INFORMATION** section at the beginning of this manual including all text under subheadings therein before set up or use of this product.

### **WARNING** TO PREVENT SERIOUS INJURY

#### FROM ACCIDENTAL OPERATION:

Turn the Power Switch of the tool to its "OFF" position and unplug the tool from its electrical outlet before assembling or making any adjustments to the tool.

**Note:** For additional information regarding the parts listed in the following pages, refer to the Assembly Diagram near the end of this manual.

### Assembly: Installing the Blade

1. Be sure the tool is unplugged from its power source. Wear heavy duty work gloves.

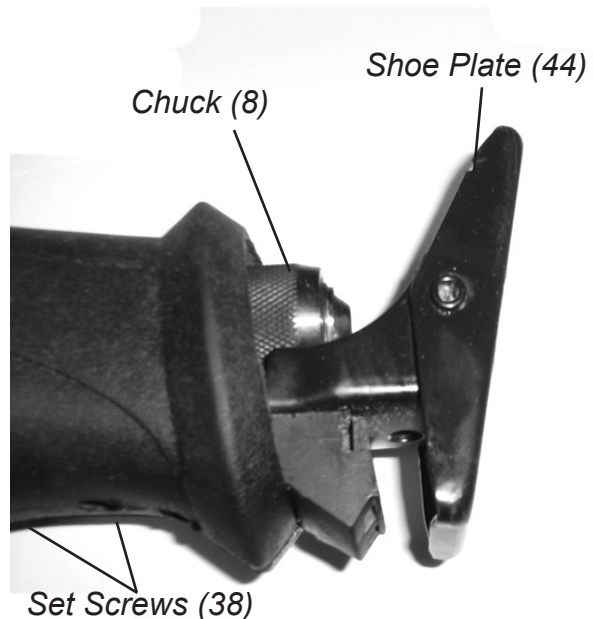

2. Select a Blade that is appropriate for the task at hand. See the Blade Selection Chart on page 14 for suggested blade size and type.
  3. Rotate the Chuck (8) counterclockwise to open it. Hold it in the open position. (See Photo previous page.)
  4. Insert the 1/2" shank of the selected Blade (43) firmly into the Chuck. Be sure the Blade is fully inserted.
  5. Release the Chuck to close it.
  6. With work gloves on, pull on the Blade to ensure that it is firmly installed. Operating this tool with a loose blade can cause injury.
2. Retracted blade length should be wider than workpiece. If the Blade is shorter, it's tip will jam in the work piece during cutting, possibly causing injury and damaging the Blade or work piece.
  3. The Base Plate (44) can be adjusted to limit the amount of Blade protrusion. Loosen Set Screws (38) located on the underside of the Front Cover (42). (See photo.) Slide the Base Plate (44) straight in or out of the Front Cover as required. Retighten the Set Screws.



*Using the Allen Key (67) to loosen the Set Screws (38) to adjust the Base Plate (44).*

## **OPERATING INSTRUCTIONS**



Read the **ENTIRE IMPORTANT SAFETY INFORMATION** section at the beginning of this manual including all text under subheadings therein before set up or use of this product.

### **Tool Set Up**



**TO PREVENT SERIOUS INJURY FROM ACCIDENTAL OPERATION:**  
Turn the Power Switch of the tool to its "OFF" position and unplug the tool from its electrical outlet before performing any inspection, maintenance, or cleaning procedures.

1. Only install a Blade that is in good condition, and is appropriate to the work you will be doing.

### **Work Piece and Work Area Set Up**

1. Designate a work area that is clean and well-lit. The work area must not allow access by children or pets to prevent injury and distraction.
2. Route the power cord along a safe route to reach the work area without creating a tripping hazard or exposing the power cord to possible damage. The power cord must reach the work area with enough extra length to allow free movement while working.
3. Secure loose work pieces using a vise or clamps (not included) to prevent movement while working.

4. There must not be hazardous objects, such as utility lines or foreign objects, nearby that will present a hazard while working.

### **General Operating Instructions**

1. To turn ON the tool, squeeze the Trigger (60). To turn the tool OFF, release the Trigger.
2. The tool can be set to operate continuously, by squeezing the Trigger and pressing in the Locking Button on the Handle. To stop continuous operation, squeeze the Trigger to unlock the Button and release the Trigger.
3. Be sure the work piece is firmly mounted so it will not move during the cutting operation. Support the cut off end of the work piece so it will not fall free at the end of the cut.
4. Grip the tool with both hands, one hand on the Handle (58,65), and one on the Front Cover (42).
5. Place the Blade (43) on the work piece and squeeze the Trigger (60). The saw will begin to operate.
6. Keep the Base Plate (44) pressed firmly against the work piece to prevent tool kick back.
7. Maintain a smooth motion pressing the Blade through the material as it is cut. Follow the cut, do not press too hard. If the tool slows down as it is cutting, apply less pressure on the tool.
8. When the cut is completed, release the Trigger and wait until the blade stops. If you will not be making

another cut unplug the tool and store it safely.

### **Plunge Cutting**

1. You can plunge cut into plywood and thin board panels. Do not attempt to plunge cut into thick, hard or metal panels.
2. Select a short, thick blade which is in good condition.
3. Place the tool on the work piece with the Blade NOT touching the work material. Squeeze the Trigger (60) to start the tool operating. Never start a plunge cut with the Blade tip touching the work piece. This will cause an immediate kick back, that can damage the work piece, blade or cause injury.
4. Slowly rotate the tool on the Base Plate (44) as the Blade contacts the work piece. Hold the tool firmly.
5. Continue to slowly rotate the tool until the Blade has penetrated through the work material. Press the Base Plate (44) firmly against the work material and continue to make the cut.
6. To prevent accidents, turn off the tool and disconnect its power supply after use. Clean, then store the tool indoors out of children's reach.

---

## MAINTENANCE AND SERVICING

---



Procedures not specifically explained in this manual must be performed only by a qualified technician.

### **⚠️ WARNING**

#### **TO PREVENT SERIOUS INJURY**

##### **FROM ACCIDENTAL OPERATION:**

Turn the Power Switch of the tool to its “OFF” position and unplug the tool from its electrical outlet before performing any inspection, maintenance, or cleaning procedures.

##### **TO PREVENT SERIOUS INJURY FROM TOOL FAILURE:**

Do not use damaged equipment. If abnormal noise or vibration occurs, have the problem corrected before further use.

---

### **Cleaning, Maintenance, and Lubrication**

1. **BEFORE EACH USE**, inspect the general condition of the tool. Check for loose screws, misalignment or binding of moving parts, cracked or broken parts, damaged electrical wiring, and any other condition that may affect its safe operation.
2. **AFTER USE**, clean external surfaces of the tool with clean cloth.
3. Check the condition of Blades. Bent, cracked, worn or dull blades will not operate properly and can cause

damage or injury. Discard damaged or worn blades.

4. **⚠️ WARNING!** If the supply cord of this power tool is damaged, it must be replaced only by a qualified service technician.

---

### **Replacing Carbon Brushes**

1. To inspect or replace the Carbon Brushes, remove the Brush Caps (54) located on the top and underside of the Main Housing (53).
2. With the Caps removed, the Brush Holders (55) and Carbon Brushes (56) may fall out.
3. Inspect the Carbon Brushes. They should not be chipped or cracked, and the carbon portion must be at least 1/4 in length.

*One of the Carbon Brush Caps (54)*

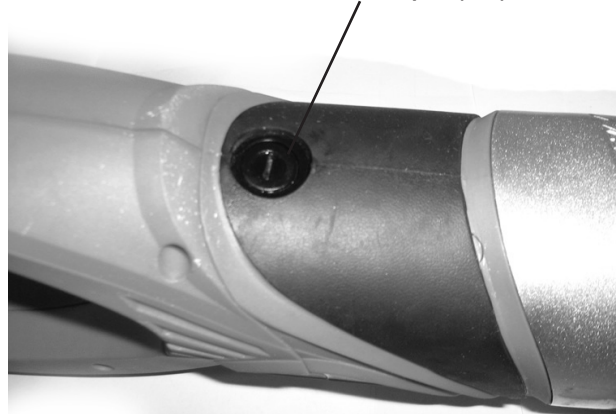

4. If the Carbon Brushes are worn or damaged, they must be replaced. Replacement Carbon Brushes are available from Harbor Freight Tools.

## Troubleshooting

<b>Problem</b>	<b>Possible Causes</b>	<b>Likely Solutions</b>
Tool will not start	<ol style="list-style-type: none"> <li>1. No power at outlet.</li> <li>2. Cord not connected.</li> <li>3. Carbon Brushes may be worn or damaged.</li> </ol>	<ol style="list-style-type: none"> <li>1. Check power at outlet.</li> <li>2. Check that cord is plugged in.</li> <li>3. Inspect Carbon Brushes and replace if necessary.</li> </ol>
Tool operates slowly or sporadically.	<ol style="list-style-type: none"> <li>1. Carbon Brushes may be worn or damaged.</li> </ol>	<ol style="list-style-type: none"> <li>1. Inspect Carbon Brushes and replace if necessary.</li> </ol>
Tool does not cut effectively or blade jams in work material	<ol style="list-style-type: none"> <li>1. Blade may be damaged, worn or wrong type for the material.</li> <li>2. Too much pressure.</li> </ol>	<ol style="list-style-type: none"> <li>1. Check condition and type of blade. Use only proper type of blade in good condition.</li> <li>2. Ease off pressure on blade.</li> </ol>



**Follow all safety precautions whenever diagnosing or servicing the tool. Disconnect power supply before service.**

## Blade Selection Chart

<b>Work Material Type</b>	<b>Blade Length</b>	<b>TPI</b>	<b>Blade Material</b>
Wood	6 - 12 inches	5 - 11	Carbon Steel
Wood with embedded nails or screws	6 - 12 inches	11	Carbide tipped Steel ("bi-metal")
Metal	6 - 9 inches	10 - 25	Carbide tipped Steel ("bi-metal") or Carbide Grit
Plastic	6 - 12 inches	9 - 25	Carbon Steel or Carbide Grit

## PLEASE READ THE FOLLOWING CAREFULLY

THE MANUFACTURER AND/OR DISTRIBUTOR HAS PROVIDED THE PARTS LIST AND ASSEMBLY DIAGRAM IN THIS MANUAL AS A REFERENCE TOOL ONLY. NEITHER THE MANUFACTURER OR DISTRIBUTOR MAKES ANY REPRESENTATION OR WARRANTY OF ANY KIND TO THE BUYER THAT HE OR SHE IS QUALIFIED TO MAKE ANY REPAIRS TO THE PRODUCT, OR THAT HE OR SHE IS QUALIFIED TO REPLACE ANY PARTS OF THE PRODUCT. IN FACT, THE MANUFACTURER AND/OR DISTRIBUTOR EXPRESSLY STATES THAT ALL REPAIRS AND PARTS REPLACEMENTS SHOULD BE UNDERTAKEN BY CERTIFIED AND LICENSED TECHNICIANS, AND NOT BY THE BUYER. THE BUYER ASSUMES ALL RISK AND LIABILITY ARISING OUT OF HIS OR HER REPAIRS TO THE ORIGINAL PRODUCT OR REPLACEMENT PARTS THERETO, OR ARISING OUT OF HIS OR HER INSTALLATION OF REPLACEMENT PARTS THERETO.

## PARTS LIST

Part	Description	Qty.
1	Phillips Pan Head Screw	4
2	Spring Washer m5	2
3	Gear Cover	1
4	Phillips Head Pan Screw	4
5	Spring Washer m5	4
6	Cover Plate	1
7	Retainer Ring	1
8	Chuck (outer Ring)	1
9	Torsion Spring	1
10	Inner Ring	1
11	Compression Spring	1
12	Pin	1
13	Spring Pin	1
14	Wool Gasket Ring	1
15	Gasket Ring Cap	1
16	Plastic Ring	1
17	Sealed Bearing	1
18	Reciprocating Lever	1
19	Middle Plate	1
20	Spindle	1
21	Needle Bearing	1
22	Cylinder Pin	1
23	Baffle Ring m7	1
24	Gear	1
25	Flat Washer	1
26	Phillips Head Pan Screw	4
27	Bearing	1
28	Phillips Head Screw	3
29	Lock Washer	3
30	Bearing Plate	1
31	Bearing 6201	1
32	Circlip for Shaft	1
33	Gear Housing	1
34	Bearing 6000	1
35	Flat Washer	1
36	Phillips Head Screw	1
37	Seal Cover	1

## PARTS LIST

Part	Description	Qty.
38	Set Screw	2
39	Spring Washer m5	4
40	Flat Washer m5	2
41	Bumper	1
42	Front Cover	1
43	Saw Blade	2
44	Shoe Plate	1
45	Rotor	1
46	Baffle Ring	1
47	Bearing 608	1
48	Bearing Sleeve	1
49	Magnesium Gear Cover	1
50	Phillips Pan Head Screw	2
51	Flat Washer m4	2
52	Stator	1
53	Main Housing	1
54	Brush Cap	2
55	Brush Holder	2
56	Carbon Brush	2
57	Name Plate (left)	1
58	Handle (right section)	1
59	Phillips Pan Head Screw	7
60	Trigger Switch	1
61	Phillips Pan Head Screw	2
62	Cable Clamp	1
63	Cable Sleeve	1
64	Power Cable	1
65	Handle (left section)	1
66	Label	1
67	Allen Key	1

### Included Blades

Wood Cutting Blade: 11 TPI, 5-3/4" Long  
 Metal Cutting Blade: 25 TPI, 3-1/4" Long



# ASSEMBLY DIAGRAM

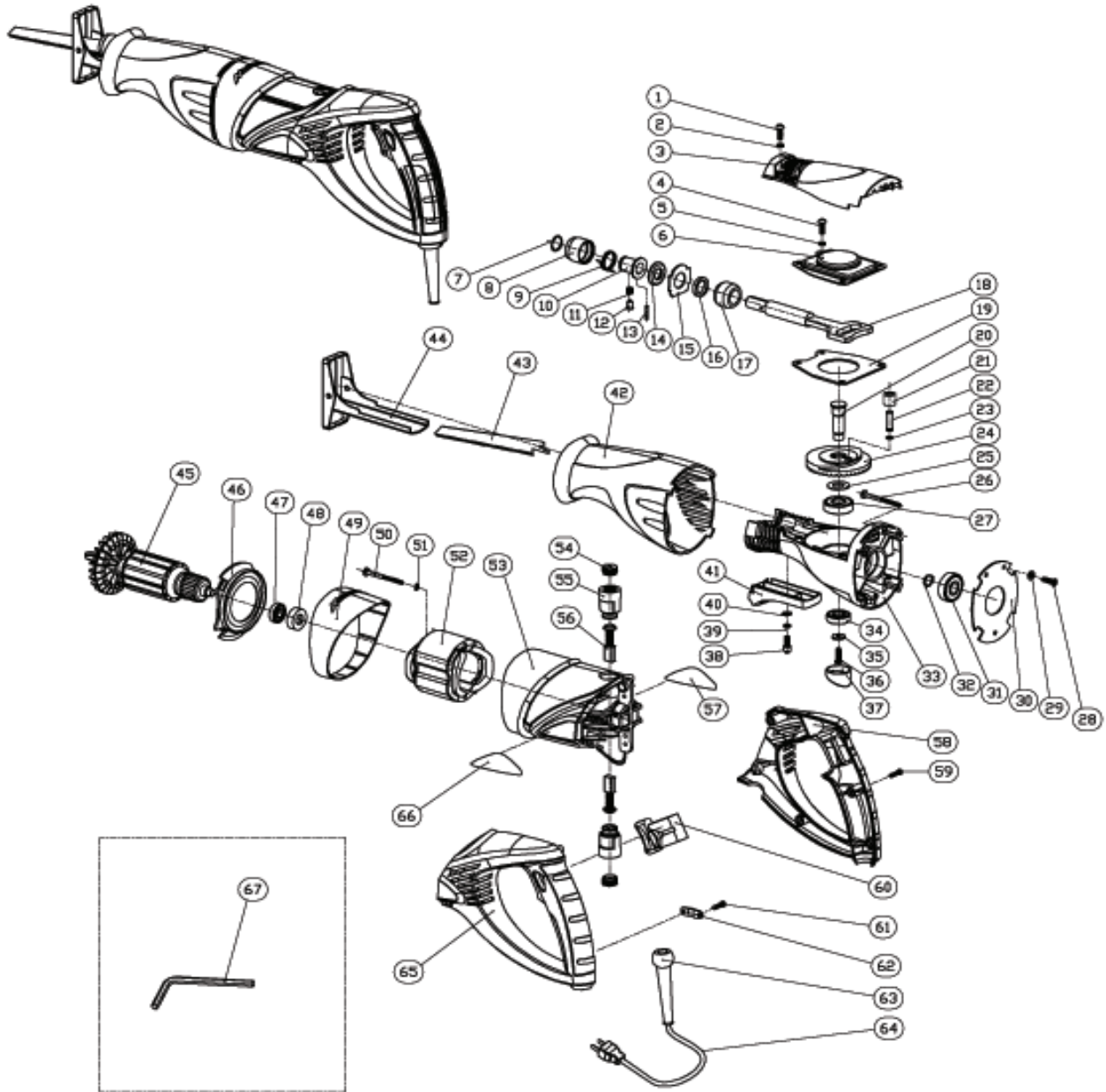

**Record Product's Serial Number Here:** \_\_\_\_\_

**Note:** If product has no serial number, record month and year of purchase instead.

**Note:** Some parts are listed and shown for illustration purposes only, and are not available individually as replacement parts.

## 90 Day Warranty

Harbor Freight Tools Co. makes every effort to assure that its products meet high quality and durability standards, and warrants to the original purchaser that this product is free from defects in materials and workmanship for the period of 90 days from the date of purchase. This warranty does not apply to damage due directly or indirectly, to misuse, abuse, negligence or accidents, repairs or alterations outside our facilities, criminal activity, improper installation, normal wear and tear, or to lack of maintenance. We shall in no event be liable for death, injuries to persons or property, or for incidental, contingent, special or consequential damages arising from the use of our product. Some states do not allow the exclusion or limitation of incidental or consequential damages, so the above limitation of exclusion may not apply to you. THIS WARRANTY IS EXPRESSLY IN LIEU OF ALL OTHER WARRANTIES, EXPRESS OR IMPLIED, INCLUDING THE WARRANTIES OF MERCHANTABILITY AND FITNESS.

To take advantage of this warranty, the product or part must be returned to us with transportation charges prepaid. Proof of purchase date and an explanation of the complaint must accompany the merchandise. If our inspection verifies the defect, we will either repair or replace the product at our election or we may elect to refund the purchase price if we cannot readily and quickly provide you with a replacement. We will return repaired products at our expense, but if we determine there is no defect, or that the defect resulted from causes not within the scope of our warranty, then you must bear the cost of returning the product.

This warranty gives you specific legal rights and you may also have other rights which vary from state to state.

**3491 Mission Oaks Blvd. • PO Box 6009 • Camarillo, CA 93011 • (800) 444-3353**